



A Negotiation Protocol in a Group Decision Support System Using a Multi-Criteria Analysis Method

Sofiane Khat and Djamila Hamdadou

EasyChair preprints are intended for rapid dissemination of research results and are integrated with the rest of EasyChair.

March 3, 2020

A negotiation protocol in a group decision support system using a multi-criteria analysis method

Sofiane Khiat Computer
Science Laboratory of Oran
(LIO).
Université Oran1, Oran (Algeria)
khiat.sofiane@gmail.com

Djamila Hamdadou
Computer Science Laboratory
of Oran (LIO).
Université Oran1, Oran (Algeria)
dzhammadoud@yahoo.fr

Abstract

Decision-making is one of the most important activities in our daily lives, especially in professional life. Faced with a decision problem, the decision-maker will have to judge and evaluate the different solutions. This means that the decision-maker must define his point of view and choose one or more solutions. A criterion can therefore be defined as the means of modelling a point of view. However, several aspects of a solution may contribute to the same point of view. Indeed, multi-criteria analysis allows the different criteria to be judged and selected. Multi-criteria analysis is therefore an important step in the decision-making process.

The main contribution proposed in this study is in the area of collaborative decision support. This activity consists in organizing, over time, the realization of interdependent tasks, taking into account temporal constraints and the exploitation of resources. The objective is to find a common agreement between the various decision-makers based on a multi-criteria analysis method PROMETHEE II. In this context, negotiation has proven to be a powerful mechanism for finding mutually acceptable compromises. For this purpose, multi-agent systems (MAS) constitute a very appropriate and powerful paradigm for modelling decision-makers' behaviour. In this study we propose a negotiation protocol based on the election for the resolution of the problem of spatial localization in territory planning (TP).

1 Introduction

The decision support tools allow to quickly verify and analyze the information in order to make the most appropriate decision at a given time. Statistics, data analysis, mathematical programming, economics and other disciplines allow to optimize solutions and go towards an optimal goal that represents the best decision. On the other hand, decision-support methods make it possible to provide information, and also to choose from among several solutions, according to established criteria, a set of solutions to solve a decision-making problem.

However, there are some very confusing issues, where making a decision is very difficult or even complicated, and this is due to several factors [Nachet14]:

- A structural complexity of decisions.
- A large number of alternatives due to the complexity of the problem.
- The impact of the decision taken can be very important, it can be economic, political, organizational, environmental, etc.
- The need for speed in decision making, it is the case of urgency medical, or military, or software installation diagnostics.

Moreover, the decision is no longer like a simple problem and of a single decision maker, but a task with several collective missions. The decision in an organization does not appear as a result provided by a single decision maker, but as collaboration between several divergent points of view.

Indeed, decisions require the expertise of several people, especially those concerned by the decision. It is, therefore, necessary to involve them in the decision-making process.

The decision-making process consists of exploiting existing resources, whether material or human, in order to find a useful recommendation. This is achieved by going through several steps of validation (modification of the choice of a solution), depending on the nature of the decision while choosing a resolution approach. A decision-making process is a technique that allows experiments to be carried out in order to reach a solution by choosing the best among the alternatives evaluated. The application of this technique has led to the emergence of decision support systems (DSS).

The aim of these systems was to solve problems by searching for an optimal solution, by calculating the maximum or minimum of mathematical functions expressing an objective to be reached. Thanks to progress in computer science, one of the evolutions of decision support systems has been to get closer to users to allow them to intervene in the decision-making process [Younsi08].

Group Decision Support Systems (GDSS) or "multi-participant decision support systems" have, in addition to the DSS, cooperative components and negotiation protocols. In the literature, there are various definitions that have highlighted the interest of GDSS in professional organisations. This type of system represents the core of our research work in this study. A GDSS is "a set of technologies that support the activities carried out by decision-makers organized in a group" [Ould mahraz12]. In addition, one of the most important tasks is to select the necessary elements to be considered in decision-making. In other words, these elements are considered as a solution to a decision-making problem, which can be put in a specific context where these elements are of spatial type representing geographic information. Spatial decision support systems (SDSS) are interactive systems designed to support a user or group of users in achieving higher efficiency in decision making while solving a semi-structured spatial decision problem.

Territorial planning is one of the most important activities in spatial decision support systems. One of the challenges for planners is to achieve an optimal balance between the needs of our societies and the responses offered by planning works. There are many aspects and difficulties involved in this matching: identifying needs, choosing which ones will be met, and allocating sites according to a number of constraints and criteria. All these issues give rise to wide-ranging environmental, economic, social and political debates [Igor04].

The realization of spatial localization in TP relies on mathematical methods and computer tools such as geographical information systems (GIS). The application of GIS is oriented to several areas: urban development [Frail16], environmental management [Lebars03], the territory evaluation [Hamdadou07], industrial diagnosis [Hamdadou11] etc.

More particularly, spatial decision support systems are interesting, especially in the development of a model of group decision support which is dedicated to the problems of space localization in TP: the problem which entails the search for a surface on a geographical map satisfying a set of criteria and finding a compromise between several interests that appeal to the expertise of several people, particularly those which are concerned by the decision.

However, the group of decision-makers will be modeled by a set of entities called computer agents. These agents represent each decision-maker in a multi-agent system (MAS) [Ai04] [Nachet14].

The problem addressed in this study is to propose a system that models the different decision-makers. Each decision-maker has their own information, preferences and objectives that are generally not shared or communicated. A distributed decision-making process is set up between the different entities involved and impacted by this group decision.

The resolution of this problem then consists in finding a decision common to all decision-makers. Hence the need for a negotiation process integrated into a Group Decision Support System (GDSS) which makes it possible to find a common agreement to be found for this group, when faced with a conflict. Several reasons can be given for having a common objective, of which we cite:

1. **The multi-criteria nature of the decision-making problem** makes it possible to identify and measure alternatives (possible solutions) on which the decision will be based.
2. **The geographical distribution** of the actors involved in the decision. Decision-making can thus bring together decision-makers distributed over one or more sites.
3. **The limited temporal dimension (a defined period of time)** implies a beginning and an end to the activity and is therefore ensured by an evaluation strategy and communication means.
4. **Negotiation in a group of decision-makers** which consists in facilitating the tasks of choice between several solutions. This part requires the intervention of a coordinating entity representing a mediating actor of decision.

The work addressed in this study is part of the work on Interactive Group Decision Support Systems (IGDSS). This document is organized in four parts. In section 2 (State of the art synthesis) illustrates the basic concepts related to this study. We present a literature review on group decision support systems, their characteristics, and their topological evolution. In section 3 (contribution) we propose solutions related to the problem of our proposal for a distributed group decision support system. In section 4 (The proposed negotiation process in group decision supports system) we describe how the proposed protocol works. In section 5 (process and design) is dedicated to the description of the design and implementation of the proposed approaches.

Finally, we end this work with a conclusion in which we show the contributions of our research and we present some perspectives for possible future work.

2 Related works

The presented work is integrated in the context of Decision Support Systems (DSS). The latter is presented in two levels: the individual decision and the collective decision.

The individual decision: it is specific to a single decision maker or a human expert, Solving the problem follows a pre-established decision support process that is based on breaking down the problem into tasks and subtasks to have a satisfactory solution.

Several works on decision support systems using multi-criteria analysis methods with a single decision maker have been proposed:

In [Boukheroub12], the authors presented a method of multicriteria decision support to evaluate the decision of internalization / outsourcing as a part of a sustainable development strategy and they evaluate the strategic importance of the activities. The proposed method makes it possible to calculate an overall performance index by using the method AHP (Analytical Hierarchy Process) with indicators. In [Doumpos10], the authors presented a case study on the implementation of a multi-criteria approach to the performance and risk exposure of a bank. The proposed methodology is based on the PROMETHEE II method implemented in an integrated decision-making system.

In the same optics as our research, other studies have been conducted by exploiting geographic information systems (GIS): In [Natividade07], a methodology for evaluating built-up urban space was proposed (authors developed a decision support system for housing valuation). This system integrates a problem editor, a database management module, a set of multi-criteria decision support methods and an adequate human-computer interface that can be integrated with GIS tools. In [Taibi07] a fuzzy hierarchical analysis method (FAHP) combined with a geographical information system (GIS) has been proposed. The authors presented a process for ranking industrial sites in Algeria. The proposed process of decision-making is based on the AHP method. Also the GIS is used to prepare geographic data in screening phase and to visualize ranked zones on a map in the evaluation phase.

Individual decision does not always reflect reality because decision making does not concern a single decision maker, which has enabled the development of group decision support systems. The latter involves a set of decision makers, sometimes dispersed geographically, with different points of view and conflicting objectives are involved. Consequently, we identify the second level, namely collective decision.

The collective decision: concerns the collaborative aspect, because it consists in providing collective decision support, where each decision-maker is involved at every step of the decision-making process. In the associated literature, several works have attracted our attention:

In [López17], a group decision model based on ELECTRE GD has been proposed. It is a group decision method constructed on ELECTRE III. The proposed model generates a collective solution that helps decision makers with different interests to reach (through an iterative process) an agreement on how to classify their alternatives.

Other works have been invested in coordination between decision-makers, for a global decision-making, which was considered as a common interest. In [López16] the authors set up a web-based multicriteria decision support system, which solved multi-criteria arrangement problems in a collaborative group of decision makers in sequential or parallel coordination mode and in a distributed and asynchronous environment.

Cao and all [Cao04] propose a theoretical vision of coordination in the use of the multi-criteria tools for the decision support system (DSS) intended for the groups. The authors proposed an extension by formulating parallel and sequential coordination methods for the distribution of multi-criteria tools. These methods can be used by DSS users to coordinate and structure the distribution of multi-criteria tools for groups.

In a context of simulating the behavior of decision-makers, several researchers have proposed group decision support systems (GDSS) with architectures based on multi-agent modeling (MAS). The decision-makers are modeled in such systems by intelligent agents. Below, we are going to identify some works on this aspect:

In [Ai04], a three-layer system structure had been proposed. This structure allowed for the implementation of a distributed intelligent decision-making system for a marketing decision. The authors developed the marketing system supported by a distributed decision support. The author in [LEBars03] made a simulator based on a multi-agent system whose objective was to provide the negotiators with an instrument to test the consequences of a regulation in order to reach an acceptable compromise.

The modelling of decision-makers by intelligent agents in a group decision support system is a very interesting field in current research because it has become more important especially when the data are of spatial type (geographic area). Several researchers have proposed GDSS models to address spatial location issues by considering a set of decision-makers. However, few are the works that considered the multi-criteria aspect and the multi actors aspect at the same time [khiat, 2019]. The main existing works in the literature were carried out in our research team. Consequently, we are going to quote the most significant works carried out:

In [Hamdadou07], the authors proposed a study to optimize decision quality in the context of spatial data management using a decision support model based on Choquet integrals. The proposed model allowed experts to select suitable alternatives by modeling negotiation and multiparty participation using multi-agent systems. In [Hamdadou16], the authors proposed a strategy for the design and development of a spatial group decision support system and multicriterion. A multi-agent modeling (MAS) with a negotiation protocol based on mediation is proposed to conduct the spatial localization process. The latter was implemented in the territory planning. In [Oufella18], the authors proposed a decision support system in a spatial, multi-criteria and multi-actor context. This system has a negotiation protocol based on argumentation which stages two types of agents, a set of participating agents (actors) capable of generating decision-making arguments and an initiating agent with an argumentation system that evaluates the decision-making arguments and selects the most acceptable ones.

In the same view, the main objective in [Madouri19] is to propose a communication model between the different agents called ARGGDSS (Argumentative Group Decision Support System). The latter exploits two methods of multi-criteria analysis: the total aggregation method AHP in order to assign weights to the criteria and the partial aggregation method ELECTRE III in order to classify (rank) the variants (possible solutions) from the best to the worst and then select the action(s) that seems (or seem) the most adequate. The authors in [Abdelhadi19] proposed a communication platform for a GDSS using web services, and integrating a negotiation protocol based on mediation and multi-criteria analysis.

Several decision support systems have been proposed using multi-criteria analysis methods. In the computer science laboratory of Oran (LIO), work based on multi-criteria methods has been widely discussed. In fact, in [Zemri14], the authors' objective was to integrate multi-criteria analysis methods (MCAM) into a decision support system based on SOLAP (Spatial On-Line Analytical) technology. Processing), which has been modeled and implemented as part of decision support systems dedicated to epidemiological surveillance. The study presented in [Alnafie13] proposed an optimization of the ELECTRE III multi-criteria method by the Ant colonies. In [Bensalloua18], the authors implemented a spatial decision support system called "Silvicultura" to facilitate decision-making in complex situations. This approach is based on the integration of multi-criteria analysis and SOLAP in order to enrich the spatial analysis.

In addition, most GDSS are implemented centrally, and the proposed solution is given in the form of a recommendation guided by a coordinating entity. However, in reality, the environment of a collective system is both non-deterministic and disturbed. To this end, the use of data mining has been proven in our work, this technique has allowed us to structure the negotiation and coordinate the decision-making entities. To this end, we present in this section, some research work on data mining within decision support systems.

The authors in [Dahmani11] proposed a tool for filtering useful rules based on rule schemes previously chosen by the expert in the field. They used an ontology to extract useful knowledge. In the research work carried out in [Mokeddem16] two contributions have been proposed: the first is to propose an algorithm for the relevance analysis of traces using a genetic algorithm. The second contribution concerns trace mining, it is based on research in medical decision support in order to propose a trace-based clinical diagnosis support system.

Lastly, in a coordination strategy, it is obvious that a negotiation by proposal of solutions cannot be buckled to infinity. As a result, the strategy that we proposed takes into account time parameter and proposes a policy of the time management.

Claude Duvallet [Duvallet04] was mainly interested in the study of the real time aspect in multi-agent systems. He proposed ANYMAS model (ANYtime MultiAgents System) for the design of a real-time multi-agent system (RTMAS) based on the use of anytime algorithms.

In this study, we propose a negotiation protocol in a group decision support system. the latter is based on multi-agent modeling. The decision makers who engage in decision making can be geographically remote (distributed), where each decision maker is modeled in this system by an intelligent agent. All agents follow a collective decision support process guided by an elected coordinator agent.

3 Contribution

In the present study, we place ourselves in the context of critical decision-making situations where collective decision-making activities are generally characterized by synchronous cooperation sessions within distributed environments, related to problems of the multiplicity of decision-makers and the diversity of their preferences.

The members who have different interests, skills, and experiences express their preferences in the form of a choice between several possible solutions to several criteria, which can relatively be of different nature: economic, social, environmental, technical ect. Decision making requires a synergy of efforts from several members, so that each one of them can use their know-how.

The spatial decision-support system that we propose is very interesting, particularly in the development of a group decision-support model dedicated to the problems of spatial location in PT: the problem of searching for an area on a geographical map satisfying a set of criteria and finding a compromise between several decision-makers.

In this study, we are interested in solving a group decision support problem whose nature of the data is spatial. To this end, we have proposed a cooperative decision-making approach which provides a mutually acceptable flexible solution, in order to take account of the time constraints of the decision-making problem addressed.

The proposed system exploits the paradigm of multi-agent systems. The proposed modeling of the GDSS decision support problem considers that each agent in the MAS modeling the GDSS has decision-making autonomy to manage its own local behaviour while cooperating with other agents to arrive at an acceptable global solution. Our choice for MAS modelling is, mainly, motivated by the means of communication between agents (the decision-makers in our case) offered by this model.

The proposed approach also allows decision-makers to introduce their subjectivities through their own machines, where each machine is assimilated to an agent.

Initially, each agent manages a set of tasks with knowledge about their own data allowing them to establish their own local ranking through the multi-criteria analysis method. The agents being autonomous, their decision making is guided by the constraints of choice of the quality of the proposed solution, and to converge towards a cooperative compromise solution. It follows that the behaviour of each agent is governed by a mechanism of interaction, translated by a negotiation protocol ensuring a coherent collective decision making.

Indeed, our objective is to propose mechanisms of cooperation between agents by electing one agent among the group of agents in order to ensure consistency in decisions that are locally taken. This new approach is encouraging because it looks like the way humans negotiate. During a negotiation, the proposed solutions allow the agents to interact with an offer or a proposal related to their points of view, and their preferences. The main objective of our contribution is to:

- Design, develop and implement a negotiation protocol in a Group Decision Support System (GDSS).

Other more specific objectives are targeted:

- Represent the multiplicity and diversity of criteria and decision-makers.
- Take into consideration the temporal aspect of the decision.
- Design a coordinator.

4 The proposed negotiation process in GDSS

The objective of our work is to propose a group decision-support system modelled by a multi-agent system (MAS). Negotiation makes it possible to reproduce the behaviour of a group of decision-makers. Data mining techniques have been integrated into the proposed GDSS to address the coordination issue.

The system proposed in this study allows:

- The modeling of the preferences of each decision-maker;
- The exploitation of a method for classifying solutions (alternatives) for their assignment in predefined categories.
- The representation and modelling of decision-makers' behaviours through the use of simulation systems, in particular MAS.
- The use of supervised learning methods resulting from data analysis (decision trees) to ensure the election of the negotiator.

For that, we implement a distributed group decision support system operating in three main phases: (1) Data processing ; (2) modelling of decision-makers by agents; and (3) negotiation between agents. The proposed system is illustrated in figure1.

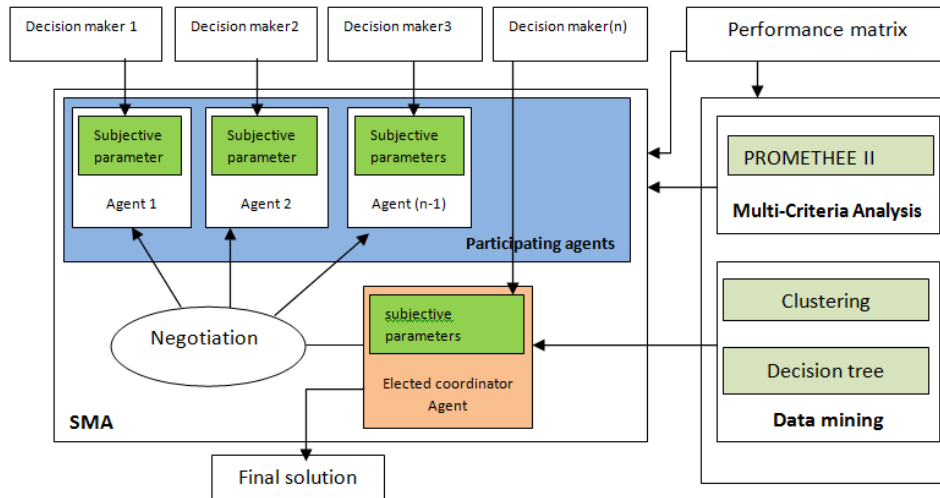

Figure 1 Proposed GDSS architecture: overview

The “Data processing” phase makes it possible to explore and use a multi-criteria analysis method in order to model the subjectivity of decision-makers. This phase also allows choosing a coordinator by exploiting data mining methods. The second phase “modeling of decision-makers by agents” models each decision maker by an agent. The last “negotiation between agents” phase results in a compromise between the agents.

In this section, we present the approach illustrating the collaborative decision-making process based on our observations and our analysis of the models proposed in the literature [Lemiere10], [Cao04] and adapted to our design of cooperative decision support modules. The model we propose is capable of supporting the proposed decision-making process. We describe each module involved in the architecture presented in Figure 1.

4.1 Multi-criteria analysis module

Multicriteria analysis (MCA) makes it possible to deal with the multiplicity, divergence and nature (quantitative or qualitative) of the criteria in order to reach acceptable compromises [Hamdadou11]. MCA is based on a coherent of criteria’s family constructed and started from a set of consequences or evaluation (performance) of each alternative of $A = \{a_1, a_2, \dots, a_n\}$ on a family of criteria $F = \{g_1, \dots, g_n\}$ which is provided by $g_j(a_i)$. These evaluations can be summarized in Table I. The application of this definition is called a Table of Performance (Performance Matrix “PM”).

TABLE I. PERFORMANCE MATRIX

	g_1	g_2	$g(n)$
a_1	$g_1(a_1)$	$g_2(a_1)$	$g_n(a_1)$
a_2	$g_1(a_2)$	$g_2(a_2)$	$g_n(a_2)$
.....
$a(n)$	$g_1(a_n)$	$g_2(a_n)$	$g_n(a_n)$

In our study, we have opted to use the PROMETHEE II multi-criteria analysis method [Brans82] which consists of ranking the alternatives in order of preference. It seeks to obtain a complete pre-order on set A of each participant, who must introduce his preferences (in the form of subjective parameters), depending on the application and the situation treated. The PROMETHEE II method allows to rank the alternatives (solution) in a vector of preference (VP) from the best solution to the worst solution.

4.2 Data mining module

This module is composed of two steps: clustering and decision tree. The first one allows to assign to each available alternative (solution) a rank in a ranking vector. This approach is ensured by the data mining method, namely K-means to solve this problem. We summarize this step as follows:

Clustering (categorization of solutions): clustering consists of grouping objects together to build predefined categories or classes. This is done by using a set of examples named as a set of solutions or alternatives (learning set).

Decision tree: This technique allows the representation of attributes in a hierarchy. The attribute that best represents the set of solutions will be the root of the tree. Consequently, it is a question of finding a partitioning of individuals that best represents the classes of each individual. This partitioning is then presented in the form of a decision tree.

The two steps mentioned above are carried out to choose a coordinator who conducts the negotiation. The data mining method allows to choose the best criterion. This method allows to classify the solutions in a vector in a decreasing way. The main goal that leads us to apply the data mining is to elect a coordinator.

4.2.1 Election of coordinator

After having obtained the ranking of all alternatives in a vector that will be called the initial solution vector (the data mining result), this vector is compared to each decision maker's preference vector (VP) for the best similarity, in order to choose a decision maker's preference vector (among all decision makers) that contains a ranking of solutions similar to the initial solution vector. This makes it possible to choose the officer who will be responsible for the smooth running of the negotiation, called the coordinator (in MAS). Figure 2 shows this aspect.

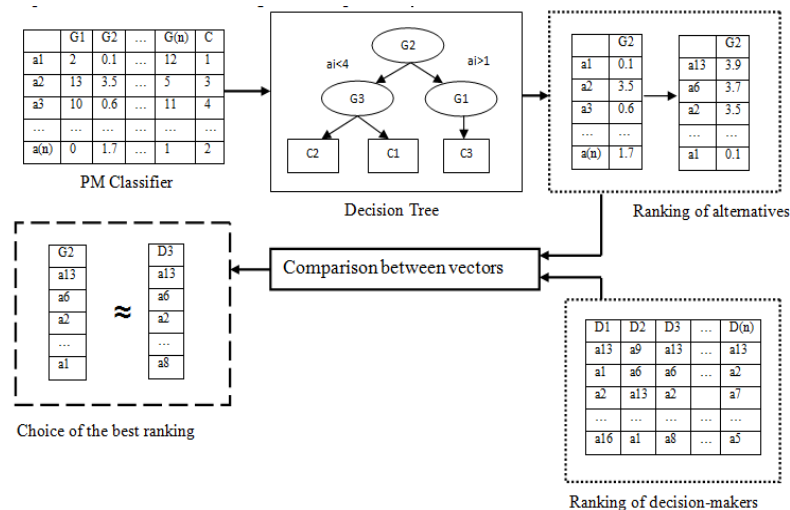

Figure 2 election process

4.3 The multi agent system module MAS

Multi-Agent Systems (MAS) are particularly appropriate when dealing with Group Decision Support Systems (GDSS). Indeed, the agents make possible to reproduce the global functioning of a GDSS from the entities which compose it (GDSS) and interactions. The MAS is a tool which makes it possible to express an application and a behavior of the decision makers by autonomous agents, who play roles and render services in an organization.

The MAS allows the representation of interactions between various entities that can cooperate, negotiate, and communicate. In the context of our study, our system involves reactive agents. Each agent is controlled by a time manager for its overall operation and interactions with other agent in the platform. For this purpose, we endow the MAS module with a negotiation protocol based on the election that involves one negotiator agent (coordinator agent) among the others, and a set of participating agents who represent different actors that are involved in a collective decision.

In this class of applications, we will look for a final decision in relation to a given situation within a constrained time frame. Therefore, we will find a solution before fixed deadlines time expiries. Fig. 3 illustrates the interaction between the negotiator agent and a participating agent who is controlled by this environment.

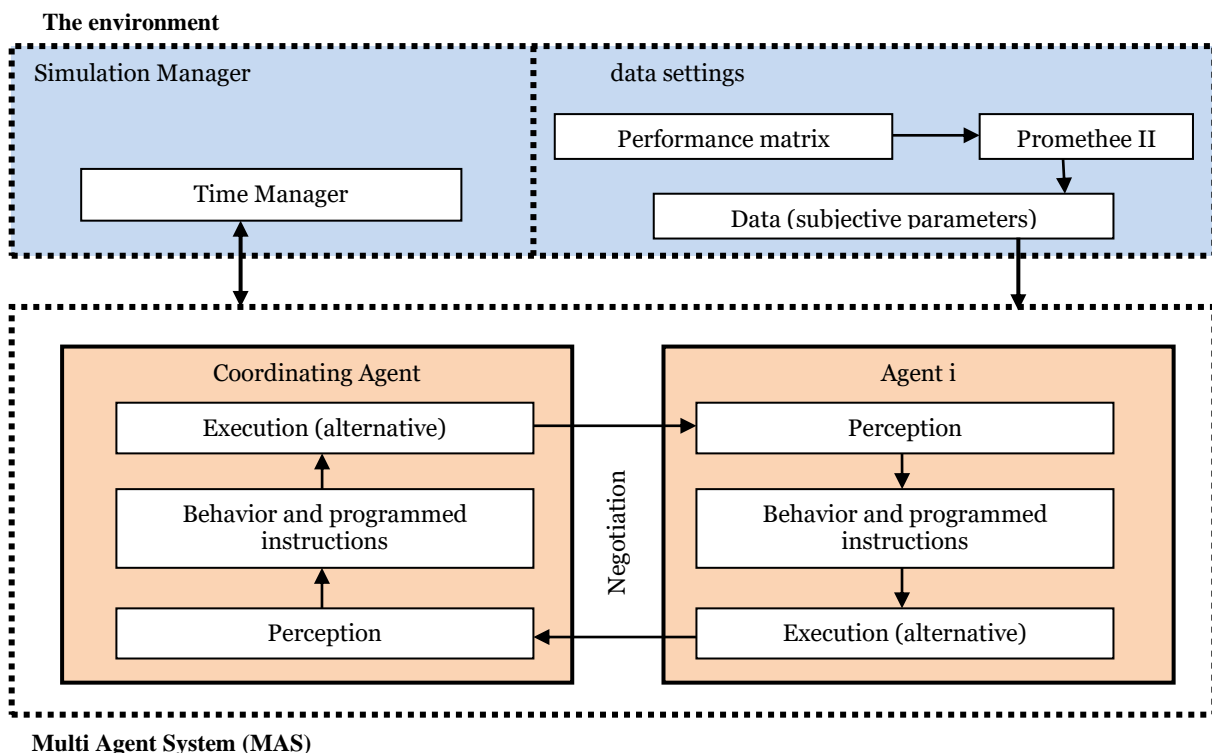

Figure 3 communication between agents

4.4 Negotiation module

Our contribution is to search for a surface on a geographical map that satisfies a set of criteria and finds a common agreement between the participants. Basically, this includes negotiation ensured by an elected coordinator, who offers solutions (alternative) from an initial vector of solutions.

In our research, we are interested in negotiation in multi-agent systems (MAS). In such a system, negotiation can resolve conflict situations between participants through the following features:

- The proposal of solutions (alternative) through a negotiation protocol that can be conducted directly from individual to individual [Lander93].
- The use of a coordinator [Sycara92]: the process of negotiation based on sending messages between a coordinator and participants through a protocol is the most widely used, easily adapted one that actually models the way humans react to each other.
- The election of a coordinator among all participants to decentralize the negotiation protocol and distribute it.

5 The proposed approach

As mentioned above, each decision-maker is assimilated to an autonomous agent who manages his own local ranking (ranking of alternatives). Each agent cooperates with the other agents in order to arrive at the solution of the decision-making problem.

The behavior of the participating agent is therefore simple since it only intervenes to send responses to the coordinating agent. On the other hand, the behavior of the coordinating agent is much more difficult to implement, since he goes through several situations such as election or negotiation.

In our study, an acceptance threshold is set at (70%). If the majority accepts a proposal that means the solution is chosen. For this purpose, the system signals the end of the negotiation and that the solution of the problem has been found. The different messages exchanged between the coordinator and the participants during the negotiation process which are shown in Figure 4 and provided by the functionality of the SMA module (the sniffer agent).

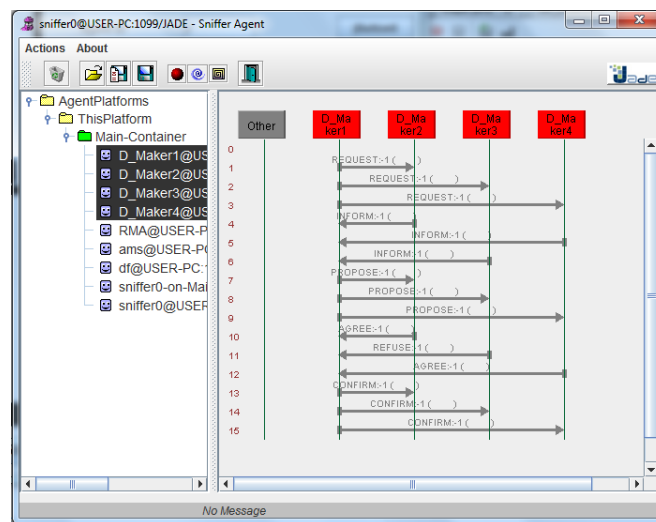

Figure 4 The messages exchanged during the negotiation process via the sniffer

6 Conclusion

In conclusion, we have tried to develop a new collective decision-making approach which includes:

- Data mining techniques, including clustering, which allows the management and manipulation of resources, in order to optimize the quality of negotiation in a spatial and multi-decision maker context.
- Multi-criteria analysis methods in a multi-agent model, which reproduces the behavior of decision-makers, in order to respond to the multiplicity and diversity of criteria.

We end this conclusion by noting the different research perspectives that we intend to address in the future, namely:

- The integration of GIS (Geographic Information System) and its functionalities.
- The exploitation of spatial data in real time.
- The design of a GDSS considering distributed agents operating in real time.
- The integration of other negotiation strategies between the different agents.

References

[NACHET14] NACHET B. Modèle multi-agents pour la conception de systèmes d'aide à la décision collective, Thesis, University of Oran, 2014.

[Younsi08] Younsi.F, Proposition d'un modèle Décisionnel en Aménagement du Territoire par Utilisation des SIG et des Réseaux de Neurones. Mémoire de magister, Université Oran1, 2008.

[Ould mahraz12] Ould mahraz.A. Modele multi-agents pour l'aide a la decision de groupe. Mémoire de Magister, Université Oran1, 2012.

[Fraile16] Fraile, A., Larrodé, E., Magreñán, Á. A., and Sicilia, J. A. "Decision model for siting transport and logistic facilities in urban environments: A methodological approach." *Journal of Computational and Applied Mathematics* 291: 478-487, 2016.

[LE BARS03] LE BARS Marjorie. "Un Simulateur Multi-Agent pour l'Aide à la Décision d'un Collectif: Application à la Gestion d'une Ressource Limitée Agro-environnementale" thèse doctorat, UNIVERSITE PARIS IX-DAUPHINE, 2003.

[Hamdadou 07] Hamdadou, D., Bouamrane, K. A Multicriterion SDSS for the Space Process Control: Towards a Hybrid Approach. In: Gelbukh A., Kuri Morales Á.F. (eds) *MICAI 2007: Advances in Artificial Intelligence. MICAI 2007. Lecture Notes in Computer Science*, vol 4827. Springer, Berlin, Heidelberg, 2007.

[Hamdadou 11] Hamdadou, D. "A MultiCriteria Group Decision Support System for Industrial Diagnosis." *INFOCOMP* 10(3): 12-24, 2011.

[Hamdadou 16] Hamdadou.D et Bouamrane.K. A Spatial Group Decision Support System : Coupling Negotiation and Multicriteria Approaches. *Journal of Intelligent Decision Technologies*. Volume 10, N_2, pp 129-147, 2016.

[Ai04] Ai, W.-G., Sun, J., and Li, H. A distributed marketing decision support system based on multi-intelligent-agent. *Machine Learning and Cybernetics. Proceedings of 2004 International Conference on, IEEE*, 2004.

[Boukherroub12] Boukherroub, T., Fondrevelle J., and GUINET, A. Multi-criteria decision making for the supply chain design: A review with emphasis on sustainable supply chains. 4th International Conference on Information Systems, Logistics and Supply Chain, ILS 2012.

[Doumpos10] Doumpos, M. and Zopounidis C. "A multicriteria decision support system for bank rating." *Decision Support Systems* 50(1): 55-63, 2010.

- [Natividade07] Natividade-Jesus, E., J. Coutinho-Rodrigues, E., and Antunes, C. "A multicriteria decision support system for housing evaluation." *Decision Support Systems* 43(3): 779-790, 2007.
- [Taibi17] Taibi, A. and Atmani B. "Combining Fuzzy AHP with GIS and Decision Rules for Industrial Site Selection." *International Journal of Interactive Multimedia and Artificial Intelligence* 4(6) : 60-69, 2017.
- [López17] López, J. C. L., Carrillo, P. A. Á., and Valenzuela, O. A. "A Multicriteria Group Decision Model for Ranking Technology Packages in Agriculture." *Soft Computing for Sustainability Science* 358: 137, 2017.
- [López16] López, J. C. L., Carrillo, P. A. Á., and Chavira, D. A. G., and Noriega, J. J. S. "A web-based group decision support system for multicriteria ranking problems." *Operational Research*: 1-36, 2016.
- [Cao04] Cao, P. P., Burstein, F., and San Pedro, J. "Extending Coordination Theory to the Field of Distributed Group Multiple Criteria Decision-Making." *Journal of Decision Systems* 13(3): 287-305, 2004.
- [Khiat19] Khiat.S et Hamdadou.D. A temporal distributed group decision support system based on multi-criteria analysis. *Journal of IJIMAI*. DOI :10.9781/ijimai.2019.03.002, pp 1-15, 2019.
- [Bensalloua18] Bensalloua.C et Hamdadou.D. Spatial OLAP and Multicriteria Integrated Approach for Decision Support System : Application in Agroforestry Management. *Journal of Decision Support System Technology (IJDSST)*. Volume 10, N_3, pp 1-26, 2018.
- [Oufella18] Oufella.S. Élaboration d'un système d'aide multicritère à la décision spatiale de groupe : négociation par argumentation. Thèse de doctorat, Université Oran1, 2018.
- [Madouri19] Madouri.S. Vers un système d'aide à la décision spatiale de groupe : négociation par argumentation. Thèse de Doctorat, Université Oran1, 2019.
- [Abdelhadi19] Abdelhadi.M, Élaboration d'un modèle de négociation par les web services dans un système d'aide multicritères à la décision de groupe. Thèse de doctorat, Université oran1, 2019.
- [Zemri14] Zemri.F et Hamdadou.D. Integration of Multi Criteria Analysis Methods to a Spatio Temporal Decision Support System for Epidemiological Monitoring. In proceeding of ICAASE, pp. 116-123, Constantine, 2014.
- [Alnafie13] Alnafie.E, Hamdadou.D, Benyelloul.A, et Messaoudi.M. Optimisation de la méthode multicritères ELECTRE III par les colonies de fourmis. In Proceedings of CIP 2013, 9ème Conférence internationale Conception Production Intégrées, Tlemcen, 2013.
- [Dahmani11] Dahmani.D, Fouille des règles d'association guidée par des ontologies et des schémas de règles : Application au domaine de la production SONATRACH / AVAL. Mémoire de magister, Université des Sciences et de la Technologie d'Oran Mohamed Boudiaf : USTO, 2011.
- [Mokeddem16] Mokeddem.S. Fouille de données pour l'analyse de traces patientes. Thèse de doctorat. Université d'oran 1, 2016.

[Duvallet01] Duvallet. C, « Des systèmes d'aide à la décision temps réel et distribués: modélisation par agents », PHD Thesis, University of Havre, 2001.

[Lemiere10] Lemiere, B., Michel, P., Abriak, N. E., Haouche, L., Laboudigue, A., Alary, C. and all. "The GeDSeT project: constitution of a decision support tool (DST) for the management and material recovery of waterways sediments in Belgium and Northern France." *Déchets, Sciences et Techniques* 57: 10 p, 2010.

[Brans82] Brans J.P.»Elaboration d'instruments d'aide à la décision: méthode PROMETHEE», Université Laval, Québec, p 5, 1982.

[Lander93] Lander S. E. and Lesser. V. R. "Understanding the Role of Negotiation in Distributed Search Among heterogeneous Agents" *International Joint Conference on Artificial Intelligence (IJCAI-93)*, 1993.

[Sycara92] Sycara K. "The PERSUADER" *The Encyclopedia of Artificial Intelligence*, Shapiro J. (Eds.) New York, 1992.